

Status Hydrogen Innovation Center

27.01.2026, Chemnitz, 4. Energiedialog Chemnitz

Dr.-Ing. Nico Keller

CEO

www.hzwo.eu

Gefördert durch:



HIC gGmbH
a subsidiary of the
HZwö e.V.

Speaker

Dr.-Ing. Nico Keller

HIC gGmbH – Hydrogen Innovation Center
CEO

nico.keller@hzwo.eu

Professorship of Advanced Powertrains
Chemnitz University of Technology
Research Associate

nico.keller@mb.tu-chemnitz.de



study of Mechanical Engineering until 2016
(Bachelor + Master)

2016 until today:
Research Associate at Professorship of Advanced Powertrains

2020 until today :
Project Coordinator at HZwo | HIC (part-time)

2018 to 2023:
PhD student at the Department of Mechanical Engineering,
Chemnitz University of Technology

NEW
with beginning of 2026:
Chief Executive Officer of HIC gGmbH



OPEN ACCESS



Who we are

	European network of hydrogen experts	
	National Hydrogen Innovation Center	
	National Transformation Hub	
	Saxon Competence Center for Hydrogen Technologies	

Some „Historical“ Facts

November 2019

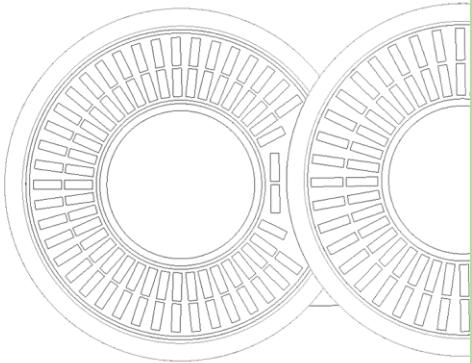

November 2020

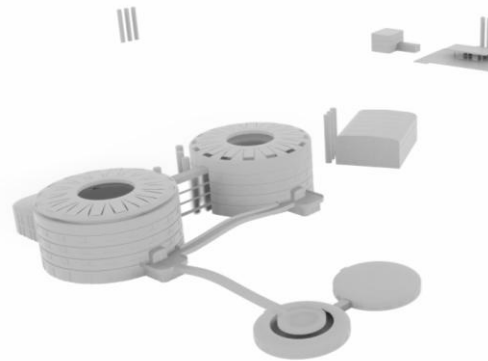

January 2021



since 2022



H₂ICC HYDROGEN AND MOBILITY INNOVATION CENTER

- B – H₂-Workshop**
Wer: TCC
Fläche: 1.100 m²
Was: FC-Testfeld für Industrie/StartUps
- D – H₂-Denkfabrik**
Wer: TUC
Fläche: 1.820 m²
Was: Büros Forscher und StartUps
- C – H₂-Lab**
Wer: TUC
Fläche: 1.710 m²
Was: H₂-Labor für Forschung



Status Project Proposal



Key data of the overall construction project:

Total usable area NUF1-7: 4.872 m²

Total gross floor area: 8.924 m²

HIC Office

HIC Lab

HIC Proving Ground



HIC Plot(s) of Land



HIC Planning Status

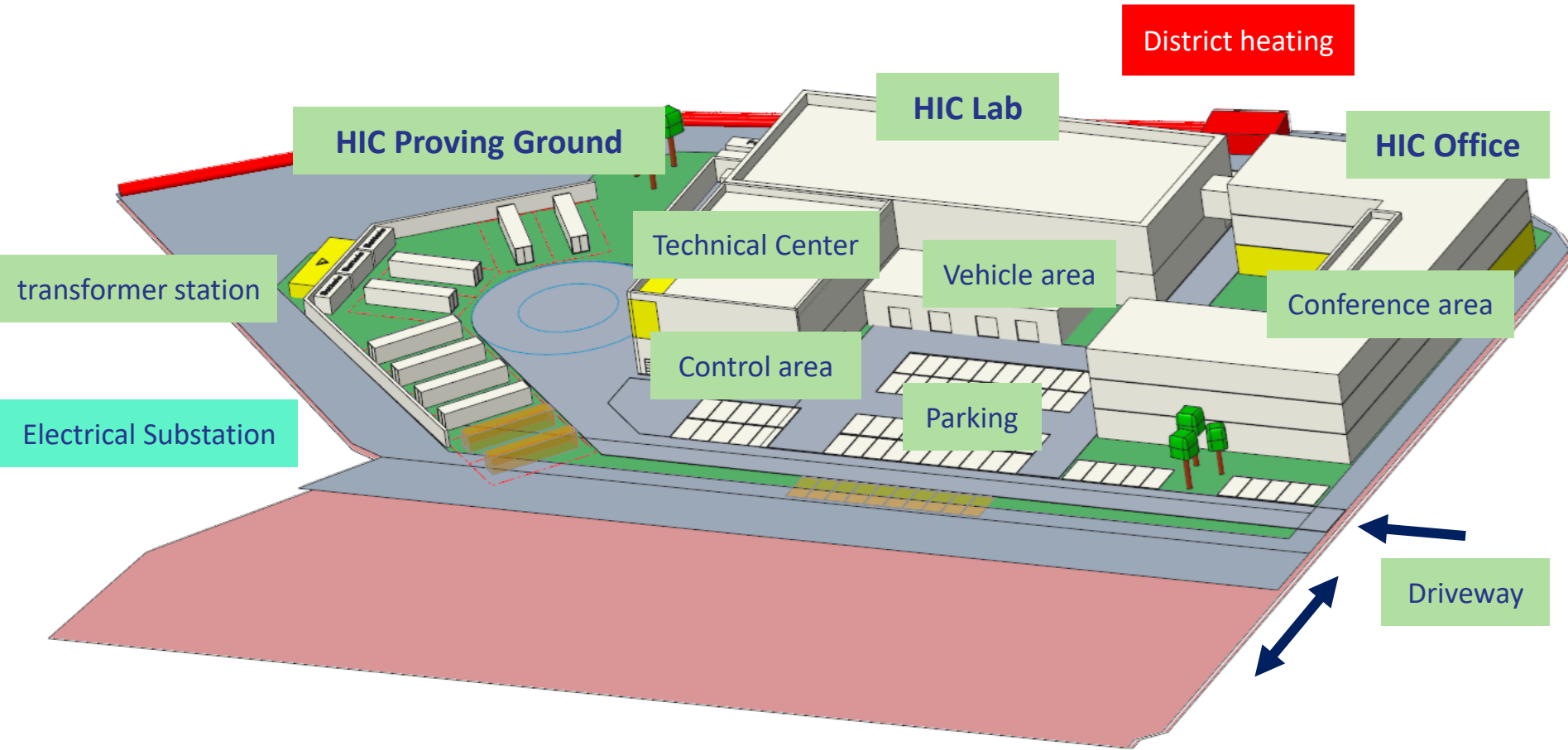

entire parcel
≈ 23.870 m²

part of the property
≈ 16.200...17.500 m²

buildable area of the property
≈ 12.300 m²

planning status

expansion potential

HIC Construction phase 1

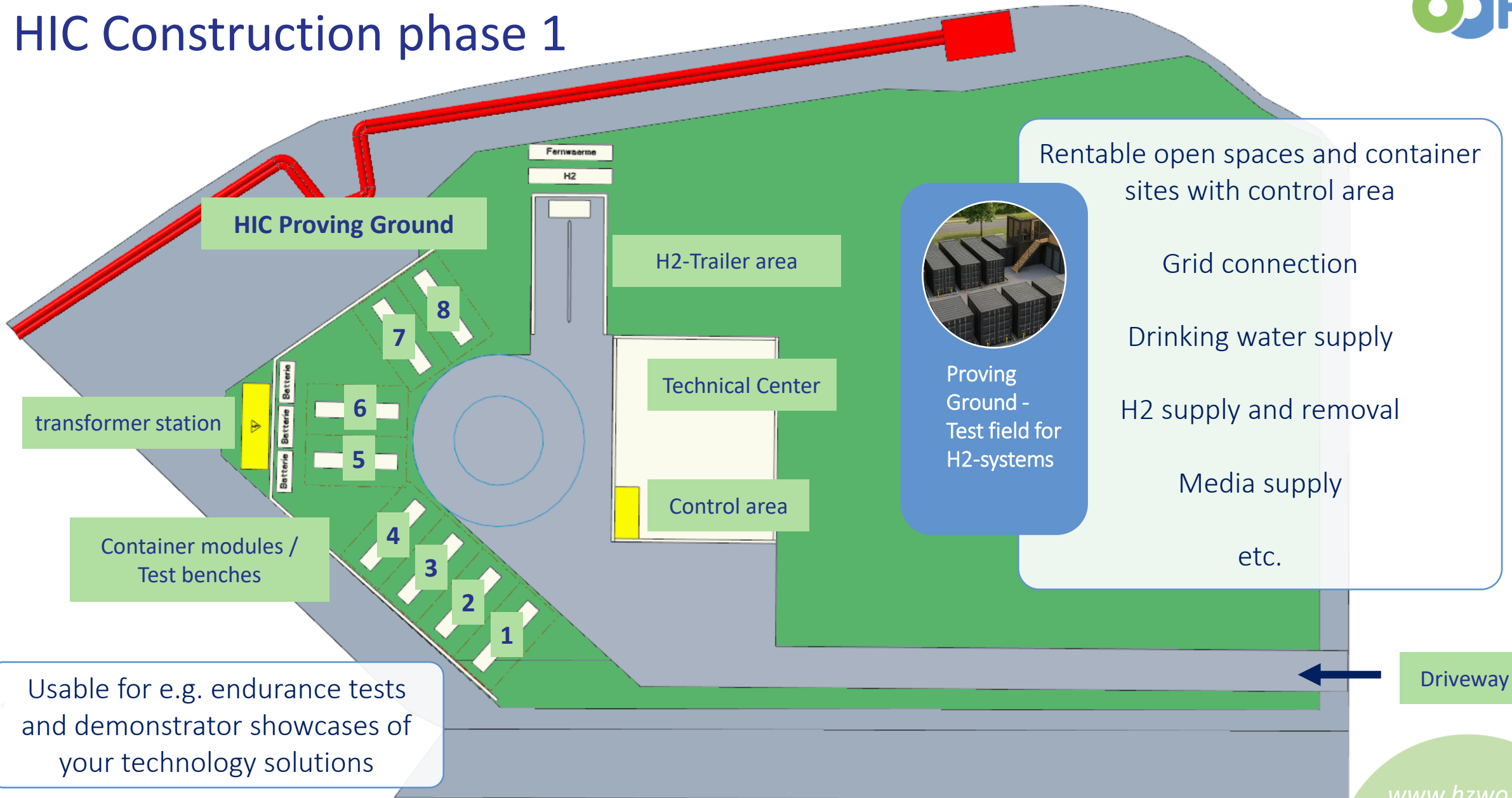

HIC Structure and Services



Research & Development
+ Transfer (R&D+T) Center
from July 2025



Proving Ground,
Lab und Office
2027-2029



Development of
FC & electrolyzer
systems, sub-
systems and
components



Feasibility and
market studies +
Patent searches,
knowledge
transfer



Proving Ground -
Test field for
H2-systems



R&D on testing
methods and
as a service



Specification
development for
components and
assemblies, **virtual
Testing**



Simulation of
components and
assemblies,
development of
testing procedures
and methods



Rentable, H2 labs,
office and
workshops



Academy
for industry
and crafts

HIC R&D+T Development path



Open Source R&D Platforms

HZwo e.V. & Partners
Over 50 projects conducted

Open Source Stack (OSS)



HIC Lab + Office

full Service providing

HIC-Stack



FC and EL

HIC-Virtual Testing



System and Facility Simulations

HIC-System

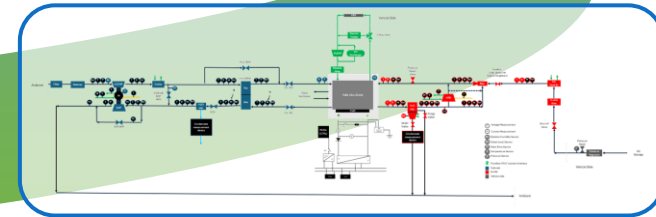

up to heavy duty applications

HIC-Virtual Testing

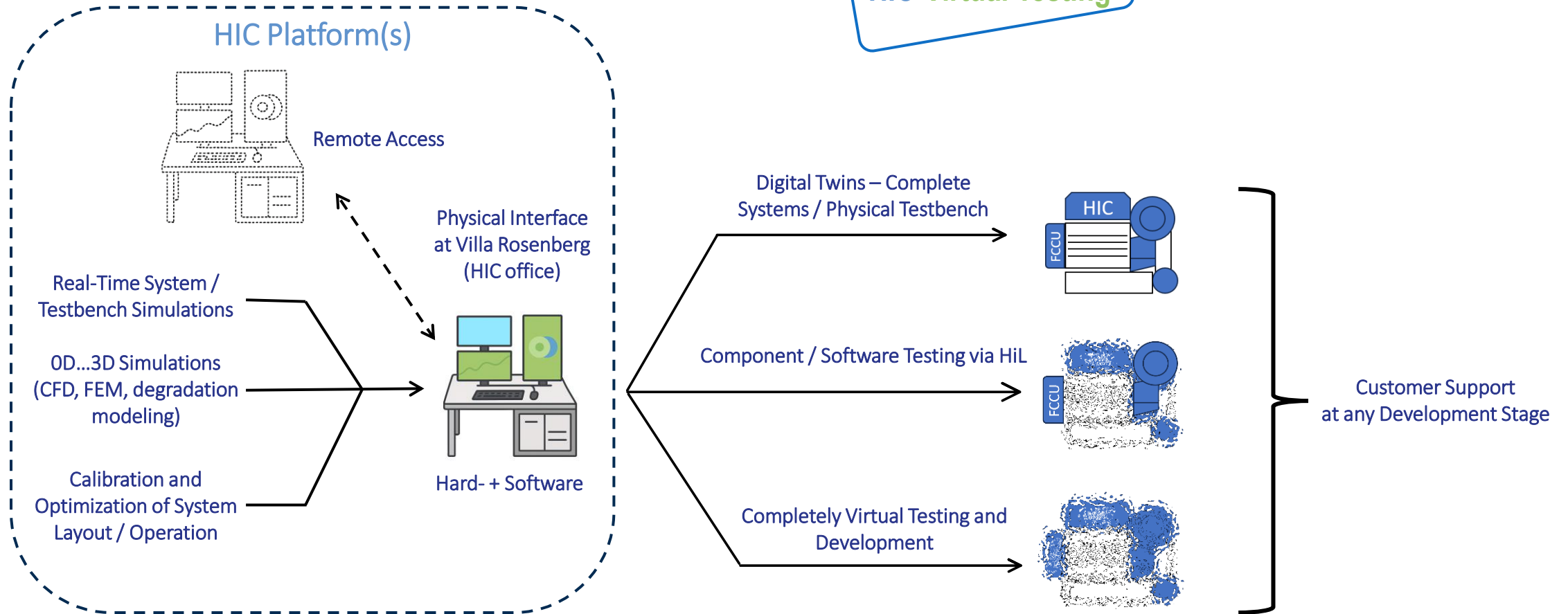

Experience provided by the HIC team

Simulation of longitudinal dynamics

- Passenger car
- Heavy-duty
- Train
- Ship



Simulation of energy systems

- interaction of
 - Fuel cell
 - Battery, supercap
- Hybrid strategies
- Thermal management

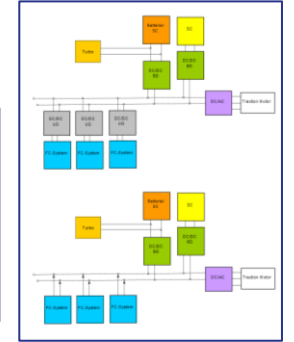
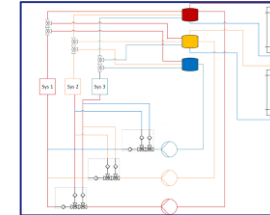

Processes in fuel cells

- V-I-characteristics and influencing drivers
- Reactant and media distribution
- Current density and temperature distribution
- Flow field design

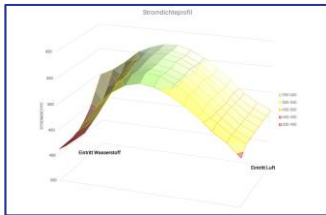

Subsystems and components

- Heat exchangers
- compressors
- Coolant pumps
- Recirculation pumps
- Water separators

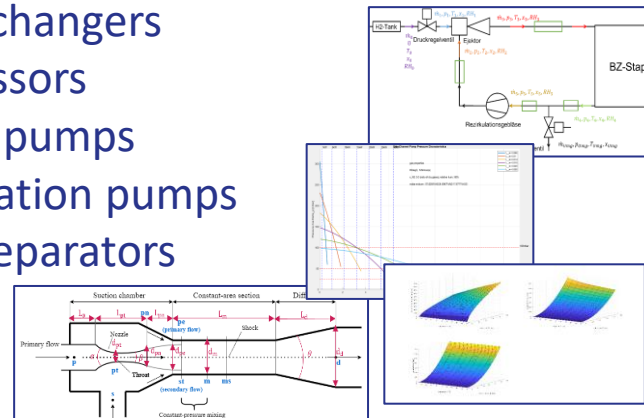

Tank systems

- Real gas behavior
- Pressures and temperatures
- Filling and emptying process

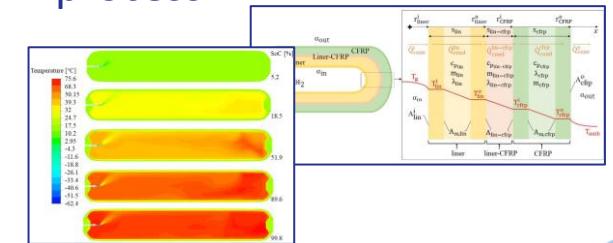

Source:
 [1] <https://www.toyota.de/entdecke-toyota/news/der-neue-toyota-mirai>
 [2] <https://www.volvotrucks.com/en-en/news-stories/press-releases/2024/may/Volvo-to-launch-hydrogen-powered-trucks.html>
 [3] <https://www.now-gmbh.de/projektfinder/wasserstoffstrassenbahn-der-neusten-generation/>
 [4] Lürssen Werft GmbH & Co. KG
 [5] <https://www.dilico.de/produkte/dilico-curr-temp/kundenspezifisch>

Timeline of Services

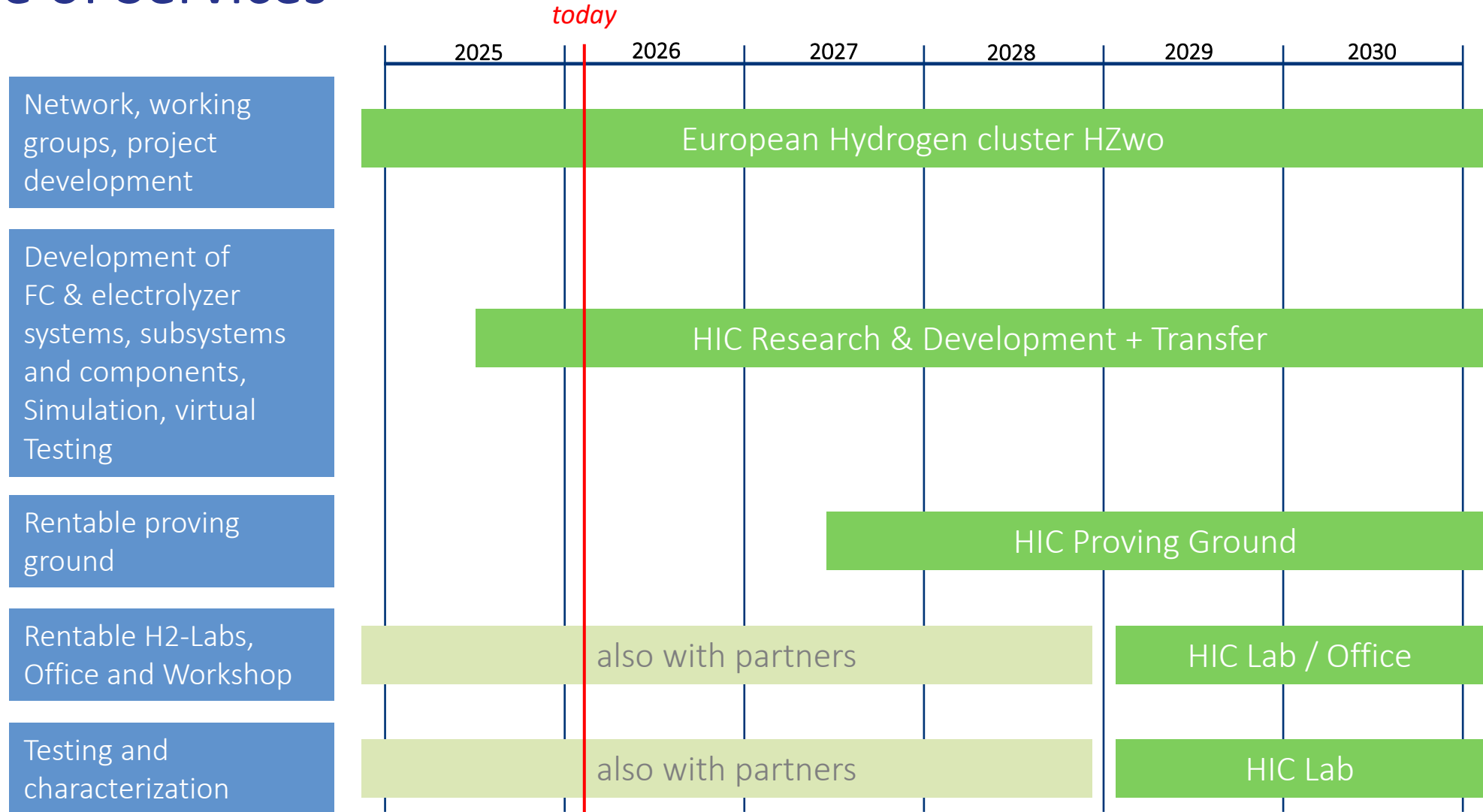

Thank you very much for your kind attention!

Dr.-Ing. Nico Keller

CEO

nico.keller@hzwo.eu



www.hzwo.eu

Gefördert durch:



HIC gGmbH
a subsidiary of the
HZwo e.V.

aufgrund eines Beschlusses
des Deutschen Bundestages